

Gövde Malzemesi Clamp Body Material	Metal + Kaplama Tipi Metal + Surface Finishing	Vida Tipi Thread Type
A Alüminyum / Aluminum	0 Kaplamasız / Uncoated	C UNC
N Polyamid / Polyamide	1 Fosfat / Phosphated / Fe/Znph	F UNF
T TPE	3 Galvaniz / Galvanized / Fe/Zn 8C Cr3-B	M Metrik / Metric
P Polipropilen / Polypropylene	4 CrNi 304 AISI 304	W Whitworth
	6 CrNi 316 AISI 316	
	9 Çinko Nikel / Zinc Nickel Fe/ZnNi	

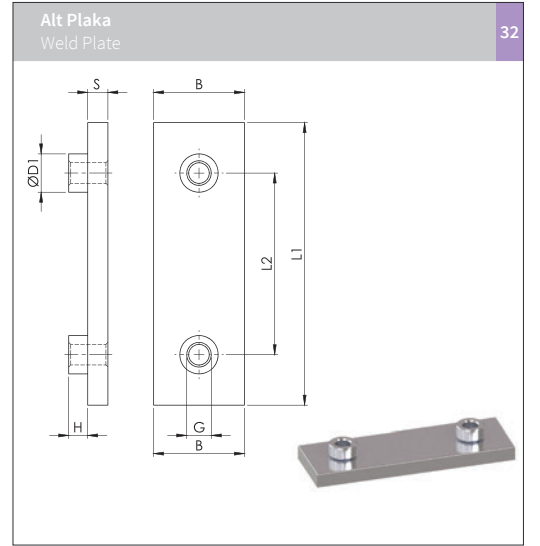
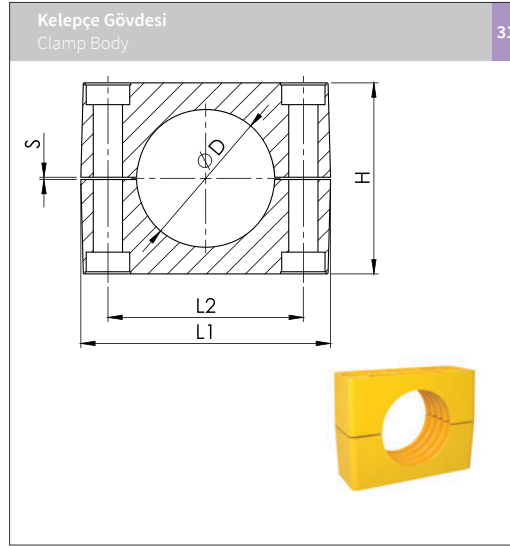

Farklı malzeme talepleriniz için lütfen LMC Makina'ya danışınız.

For different material request please consult LMC Makina.

C	2	P	1	S	A	1	X	X	X	.	X
Gövde Malzemesi Clamp Body Material	Gövde Tipi Clamp Body Design	Gövde Renk Clamp Body Colour	Grup Group	Ölçü Size							

C	A	0	0	M	3	A	1
Vida Tipi Thread Type	Metal + Kaplama Tipi Metal + Surface Finishing	Grup Group					

Grup Group	Dış Çap (ØD) O.D. of Pipe / Tube/Hose mm	Anma Çapı (R) Boru Diş Nominal Bore Pipe inch	Dış Çap (ØD) O.D. of Pipe / Tube/Hose inch
A1	6		
	6.4		1/4
	8		5/16
	9.5		3/8
	10	R 1/8	
	12		
	12.7		1/2
	13.5	R 1/4	
	14		
	15		
16		5/8	
17.2	R 3/8		
18			
A2	19		3/4
	20		
	21.3	R 1/2	
	22		7/8
	25		1
	25.4		
	26.9	R 3/4	
	28		
30			
A3	30		
	32		1 1/4
	33.7	R 1	
	35		
	38		1 1/2
	40		
	42	R 1 1/4	
A4	38		1 1/2
	42		
	44.5		1 3/4
	48.3	R 1 1/2	
	50.8		2
	55		
	57		2 1/4
	60.3	R 2	
	63.5		2 1/2
	65		
70		2 3/4	

Ölçü Tablosu Dimension Table						Sipariş Kodu Order Code	
L1	L2	H	S min.	Geniçlik Width			
55	33	32	0.6	30	C2P1SA1006.0		
					C2P1SA1006.4		
					C2P1SA1008.0		
					C2P1SA1009.5		
					C2P1SA1010.0		
					C2P1SA1012.0		
					C2P1SA1012.7		
					C2P1SA1013.5		
					C2P1SA1014.0		
					C2P1SA1015.0		
70	45	48	0.6	30	C2P1SA1016.0		
					C2P1SA1017.2		
					C2P1SA1018.0		
					C2P1SA2019.0		
					C2P1SA2020.0		
					C2P1SA2021.3		
					C2P1SA2022.0		
					C2P1SA2025.0		
					C2P1SA2025.4		
					C2P1SA2026.9		
85	60	50	0.6	30	C2P1SA2028.0		
					C2P1SA2030.0		
					C2P1SA3030.0		
					C2P1SA3032.0		
					C2P1SA3033.7		
					C2P1SA3035.0		
					C2P1SA3038.0		
					C2P1SA3040.0		
					C2P1SA3042.0		
					115	90	89
C2P1SA4042.0							
C2P1SA4044.5							
C2P1SA4048.3							
C2P1SA4050.8							
C2P1SA4055.0							
C2P1SA4057.0							
C2P1SA4060.3							
C2P1SA4063.5							
C2P1SA4065.0							
C2P1SA4070.0							

Ölçü Tablosu Dimension Table								Sipariş Kodu Order Code	
L1	L2	H	S	G	B	ØD1			
74	33	8	8	M10 3/8-16 UNC	30	18			CA00M3A1
86	45	8	8	M10 3/8-16 UNC	30	18			CA00M3A2
100	60	8	8	M10 3/8-16 UNC	30	18			CA00M3A3
140	90	8	10	M12 7/16-14 UNC	45	20			CA00M3A4